

KGU-TYPE

DIMENSIONS

KGU-3429 SERIES

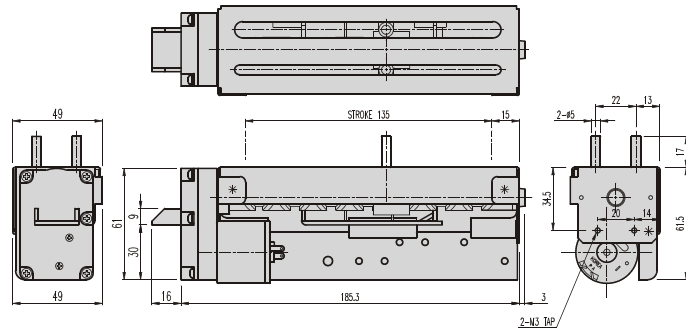

AT MAXIMUM EFFICIENCY (GEAR RATIO : 1/35)

| PART MODEL | VOLTAGE (DC) | NO LOAD | | | | AT MAX. EFF. | | | | STALL | |
|---------------|-----------------|---------|-----|--------|------------|--------------|------|-----|------------|--------|-----|
| | | mA | rpm | L (mm) | CYCLE/min. | kgf.cm | mA | rpm | CYCLE/min. | kgf.cm | A |
| KD1-3429-050 | 12V | 150 | 140 | 134 | 10 | 1 | 250 | 126 | 9 | 9,2 | 1,7 |
| KD2-3429-050 | 24V | 100 | 140 | 134 | 10 | 1 | 200 | 126 | 9 | 9,5 | 1 |
| KD1-3429-075 | 12V | 200 | 210 | 134 | 14 | 1 | 500 | 168 | 12 | 10,8 | 3,8 |
| KD2-3429-075 | 24V | 150 | 210 | 134 | 14 | 1 | 200 | 168 | 12 | 8,2 | 1,2 |
| KD1-3429-095 | 12V | 250 | 252 | 134 | 14 | 2 | 1000 | 210 | 15 | 8,5 | 3,8 |
| KD2-3429-095 | 24V | 180 | 252 | 134 | 18 | 1 | 300 | 210 | 15 | 9 | 2 |