

# 56Q

HYBRID STEPPING MOTOR  
SERIES

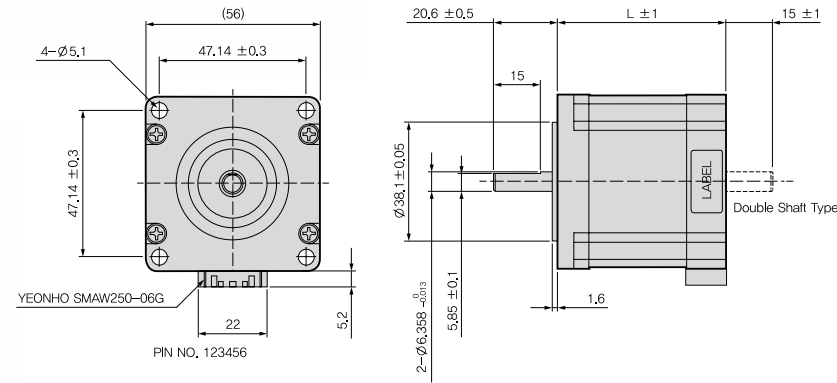

## Dimension Specification



## Wiring Diagram

### UNI-POLAR

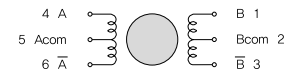

### BI-POLAR

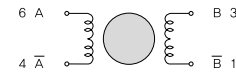

## 56Q UNI-POLAR SPECIFICATIONS

Model No. (Drive Sequence)	Step Angle (Deg.)	Rated Voltage (V/Phase)	Rated Current (A/Phase)	Winding Resistance (Ω /Phase)	Inductance (mH/Phase)	Holding Torque (kgf · cm)	Rotor Inertia (g · cm <sup>2</sup> )	Motor Length (L=mm)
4S56Q-P12042S	1.8	12.0	0.4	30.0	32.0	4.0	90	42
4S56Q-P05042S	1.8	5.0	1.0	5.0	6.9	4.0	90	42
4S56Q-P02642S	1.8	2.6	2.0	1.3	1.9	4.0	90	42
4S56Q-P01842S	1.8	1.8	3.0	0.65	0.9	4.0	90	42
4S56Q-P12054S	1.8	12.0	0.6	20.0	38.0	8.0	230	54
4S56Q-P08254S	1.8	8.2	1.0	8.2	14.0	8.0	230	54
4S56Q-P04054S	1.8	4.0	2.0	2.0	4.2	8.0	230	54
4S56Q-P02554S	1.8	2.5	3.0	0.85	1.7	8.0	230	54
4S56Q-P08576S	1.8	8.5	1.0	8.5	18.0	13.5	370	76
4S56Q-P04576S	1.8	4.5	2.0	2.3	4.3	13.5	370	76
4S56Q-P03076S	1.8	3.0	3.0	1.0	1.7	13.5	370	76

OTHER SPECIFICATIONS AVAILABLE UPON REQUEST

## 56Q BI-POLAR SPECIFICATIONS

Model No. (Drive Sequence)	Step Angle (Deg.)	Rated Voltage (V/Phase)	Rated Current (A/Phase)	Winding Resistance (Ω /Phase)	Inductance (mH/Phase)	Holding Torque (kgf · cm)	Rotor Inertia (g · cm <sup>2</sup> )	Motor Length (L=mm)
2S56Q-P09042S	1.8	9.0	0.6	15.0	32.0	5.6	90	42
2S56Q-P03542S	1.8	3.5	1.4	2.5	6.9	5.6	90	42
2S56Q-P01842S	1.8	1.8	2.8	0.65	1.9	5.6	90	42
2S56Q-P08054S	1.8	8.0	0.8	10.0	38.0	11.2	230	54
2S56Q-P05754S	1.8	5.7	1.4	4.1	14.0	11.2	230	54
2S56Q-P02854S	1.8	2.8	2.8	1.0	4.2	11.2	230	54
2S56Q-P06076S	1.8	6.0	1.4	4.3	18.0	18.9	370	76
2S56Q-P03476S	1.8	3.4	2.8	1.2	4.3	18.9	370	76

OTHER SPECIFICATIONS AVAILABLE UPON REQUEST

- DRIVER CHOPPER
- SUPPLY VOLTAGE : DC 24.0V
- 2 PHASE EXCITING
- MOUNTING WITH RUBBER DAMPER

